

DOC 302

For tractors 80-130 hp (5,5 m / 6,0 m / 6,5 m)



Hydraulic hedge mower with side shift and 90° rotating column with shock resistant hydraulic safety device for tractors HP 80/130 and weight 3500/4500 kg, suitable for working on local and trunk roads and farms.

DOC 302	5.5	6.0	6.5	S
A mm	5.500	6.000	6.500	6.000
B mm	5.700	6.200	6.700	6.200
C mm	4.400	4.500	5.400	4.500
D mm	3.500	4.000	4.500	4.000
E mm	4.300	4.800	5.300	4.800
F mm	550	550	550	550

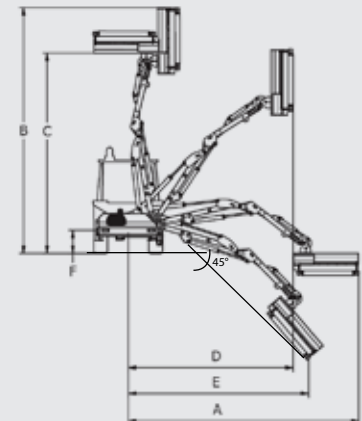

Rotor with shackle (exchangeable tools)

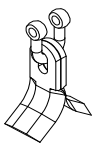

KC2
Ø max 2 cm
STANDARD EQUIPMENT

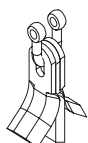

KC3
Ø max 2 cm

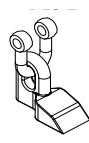

HC1
Ø max 4 cm

Rotor with bolt (exchangeable tools)

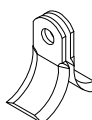

KF2
Ø max 3 cm

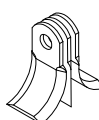

KF3
Ø max 3 cm



HF3
Ø max 6 cm

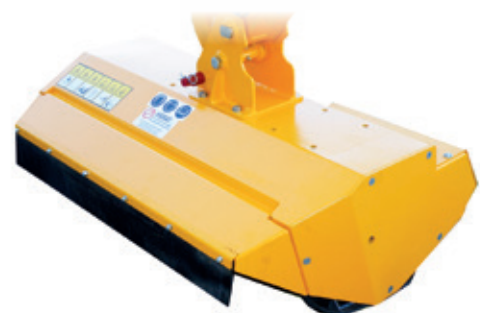

Tools n. 20 kits per rotor

Arm mower	DOC 302 5.5	DOC 302 6.0	DOC 302 6.5	DOC 302 S
Extension E mm	5.500	6.000	6.500	6.000
Weight kg	1.100	1.150	1.200	1.300
Oil tank L	160	160	160	160
Head model	30.3 TTD 125	30.3 TTD 125	30.3 TTD 125	30.3 TTD 125
Pump l/min	100+20	100+20	100+20	100+20
Hydraulic Motor HP [kW]	55 (40)	55 (40)	55 (40)	55 (40)

Tractor

Power HP [kW]	80/110 (60/82)	80/110 (60/82)	80/110 (60/82)	80/130 (60/95)
3-point linkage Cat.	Cat. 2	Cat. 2	Cat. 2	Cat. 2
Weight kg	3.500	4.000	4.500	4.500
Width m	2,4	2,4	2,4	2,4
PTO rpm	540	540	540	540

Technical features and standard equipment

- Frame - 1st arm - 2nd arm in structural steel ST 52
- 90° rotating column and shock resistant hydraulic safety device
- Three points hitch 2nd category
- Oil tank 160 l
- Double gear pump group 3+2 - 100+20 l/min
- Bidirectional hydraulic motor HP 55 power
- Distributor with remote controls with mm 3000 flexible cables
- Self-levelling floating system
- Feeler roller recordable on 3 positions
- Head rotating angle 200° with upper attachment
- Helicoidal rotor with jointed cut blade KC2
- Rotor turning at 3000 rpm
- Fixing tie-rods - Cardan joint
- Air-oil heat exchanger with radiating mass at high thermal exchange
- Rear underrun protection with lights
- Flail head mm 1250 MODEL 30.3 TTD 125 with direct transmission

Accessories on request

- Nitrogen accumulator for 1st arm suspension
- Electric distributor with joystick
- Electric rotor commandr
- Proportional power-assisted with joystick
- Cast iron pump and motor
- Rear flail head hitch
- Tie rods adapter Cat. 2
- Flail head mm 1050 - n. 16 kit per rotor

Terminal tools

In replacement of the standard mulcher

p.77



MODEL

30.5 TTD 105 | 280 kg/lbs
30.5 TTD 130 | 320 kg/lbs

30.5 TTC 105 | 305 kg/lbs
30.5 TTC 130 | 345 kg/lbs

p.82



HEDGE CUTTING BAR

BF15

p.83



PRUNING SHEAR BAR

BTZ5 15
BTZ5 18
BTZ10 16
BTZ10 19
BTZ10 22

p.84



FOREST CUTTING DISC BAR

BD2
BD3

p.85



DITCH CLEANER

PF60