

# DOC 101

For tractors 20-40 hp (3 m / 3,8 m)



Hydraulic hedge mower with side shift and mechanical release safety device for tractors HP 20/40 and weight 1000/2500 kg, with small size in phase of closing and with the possibility of several solutions of attachment: rear right, rear left, front right, front left.

<b>DOC 101</b>	<b>3.0</b>	<b>3.8</b>
A mm	3.000	3.800
B mm	3.200	4.000
C mm	2.100	2.900
D mm	1.200	2.000
E mm	2.000	2.800
F mm	550	550

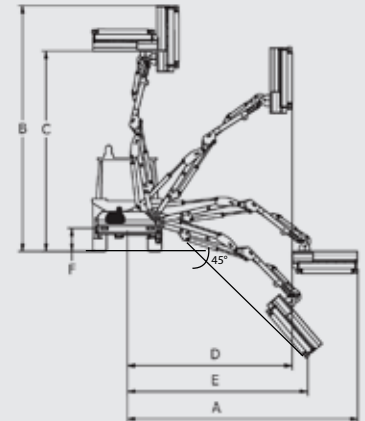

## Rotor with shackle (exchangeable tools)

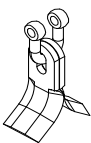

**KC1**  
 Ø max 3 cm  
**STANDARD EQUIPMENT**

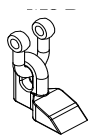

**HC1**  
 Ø max 4 cm



**HF2**  
 Ø max 5 cm



Tools n. 14 kits per rotor

<b>Arm mower</b>	<b>DOC 101 3.0</b>	<b>DOC 101 3.8</b>
<b>Extension</b> mm	3.000	3.800
<b>Weight</b> kg	400	440
<b>Oil tank</b> L	60	60
<b>Head</b> model	T3	T3
<b>Pump</b> l/min	40+15	40+15
<b>Hydraulic Motor</b> HP [kW]	20 (15)	20 (15)

### Tractor

<b>Power</b> HP [kW]	20/30 (15/22)	30/40 (22/30)
<b>3-point linkage</b> Cat.	Cat. 1	Cat. 1
<b>Weight</b> kg	1.000	1.500
<b>Width</b> m	1,00	1,20
<b>PTO</b> rpm	540	540

### Technical features and standard equipment

- Frame - 1<sup>st</sup> arm - 2<sup>nd</sup> arm in structural steel ST 52
- Three points hitch 1<sup>st</sup> category
- Oil tank 60 l
- Double gear pump group 2+2 - 40+15 l/min
- Bidirectional hydraulic motor HP 20 power
- Distributor with remote controls with mm 3000 flexible cables
- Self-levelling floating system
- Feeler roller recordable on 3 positions
- Head rotating angle 200°
- Helicoidal rotor with jointed cut blade KC1
- Rotor turning at 3000 rpm
- Fixing tie-rods
- Rear underrun protection with lights
- Flail head mm 900 MODEL T3 90 with direct transmission

### Accessories on request

- Heat exchanger
- Electric distributor with joystick
- Electric command of the rotor
- Flail head mm 700 T3 70 - n. 10 kits of tools for rotor
- Tie rods adapter

### Terminal tools

In replacement of the standard mulcher

p.82



**HEDGE CUTTING BAR**

BF15